

Assistive Listening Systems



TX-37A Transmitter

***Installation and
Operations Manual***

Gentner Communications Corporation

**Copyright
Information** 

© Copyright 1997 Gentner Communications Corporation. All rights reserved. No part of this manual may be reproduced in any form or by any means without written permission from Gentner Communications Corporation. Printed in the United States of America. Original version, 1/93. Gentner Communications Corporation reserves specification privileges. Information in this manual is subject to change without notice.

TX-37A Installation and Operations Manual

Gentner Part No. 800-402-010 (Rev. 2.1)

December 1997

Manual Development: Bill Kilpack

Artwork and Illustrations: Spindel Design, Bill Kilpack

Contents

Introduction	1
Warranty Registration	1
Product Description	2
Accessories	3
Front Panel Controls	3
Back Panel Controls	4
Installation	6
Step 1 — Antenna Connection	6
Step 2 — Audio Connection	7
Step 3 — Apply Power	8
Step 4 — Rack Mounting Option	9
Operation	9
Set Audio Level	9
High Pass Switch	10
Set the RF Level	10
Receiver Tuning	10
Reception Check	10
Interference	11
Service	11
Specifications	12
Notice	13
Warranty	13
Appendix A: System Diagram	14

List of Figures

Figure 1. TX-37A front panel controls	3
Figure 2. TX-37A back panel controls	4
Figure 3. Remote antenna connection	6
Figure 4. Amplifier connection	7
Figure 5. Y-adaptor connection	8
Figure 6. TX-37A front panel controls	9
Figure 7. TX-37A back panel controls	10

Introduction 

Congratulations on purchasing the TX-37A Assistive Listening Transmitter. The TX-37A is the heart of the Gentner Assistive Listening System. As the most advanced device of its type, its design and manufacture result from research with audiologists, sound contractors, consultants and end users. It is designed to provide the highest possible audio and RF performance. The TX-37A is reliable, easy to use and provides quality performance.

The TX-37A has audio inputs for audio sources, ranging from microphone to loudspeaker (balanced and unbalanced). It contains a series of audio processors to shape the input dynamics and frequency response. This produces clear sound for the hearing impaired, with minimal adjustment.

The RF section is crystal-controlled for long-term stability, and uses digital frequency-synthesizer circuitry, allowing the transmitter to be instantly set to 37 FCC-approved ALS channels.

If you need additional information on how to install, set up or operate your TX-37A, please contact us at Gentner Communications at the location noted below. We welcome and encourage your comments so we can continue to improve our products and better serve your communication needs.

Gentner Communications Corporation

1825 Research Way, Salt Lake City, Utah 84119

TEL: Worldwide 801.975.7200 In U.S.A. 800.945.7730

FAX: Worldwide 801.977.0087 In U.S.A. 800.933.5107

FAX-On-Demand 24-Hour Information Service 800.695.8110

FAX-On-Demand International line 801.974.3661

Worldwide Web Page @ <http://www.gentner.com>**Warranty Registration**

Please register your TX-37A *online* by visiting Technical Support at the Gentner Worldwide Web Site.

**Product
Description** 

Making sound clearer for the hearing impaired requires more than just making it louder. The needs of the hearing impaired differ from those with normal hearing. Audio processing is needed to reshape the sound. The most common impairments are reduced sensitivity and dynamic range, and loss of high frequencies. Many of the audio sources have extremely high dynamic range — often difficult to hear under optimal circumstances.

The TX-37A's audio processing is similar to that used at a commercial radio station. Automatic gain control (AGC) controls the long-term levels, equalizing different types of program material. This compensates for variations in level. The audio is tied to the AGC circuit, so incoming audio is always controlled, greatly reducing distortion.

Audio passes through a split-band compressor, reducing the signal's dynamics, making the sound not only louder but more intelligible. Normally, available compression is very limited, since too much compression creates a dull, muffled sound. To prevent this, the TX-37A splits the audio into high and low bands. It then processes them separately, so each band receives the correct amount of compression. This allows more compression overall, amplifying sound without dullness — and without noticing the compression.

After compression, the sound is fed to the patented Aphex Aural Exciter® circuit. This process has been used in the recording and broadcast industries for decades. Aphex processing creates an increase in perceived brightness for the listener. A final signal limiter is used to provide an absolute audio peak level so the FM signal can never be over-modulated (which causes distortion).

People with or without hearing impairment appreciate this sophisticated processing, with its clear sound and improved intelligibility.

Accessories ≡

Several accessory options are available including receivers, headphones, battery rechargers, portable transmitter, etc., to fit your needs. Contact Gentner Communications or your dealer for information.

Front Panel Controls ≡

The TX-37A was designed for ease in operation. The TX-37A front-panel controls (See Figure 1, below.) perform the following functions:

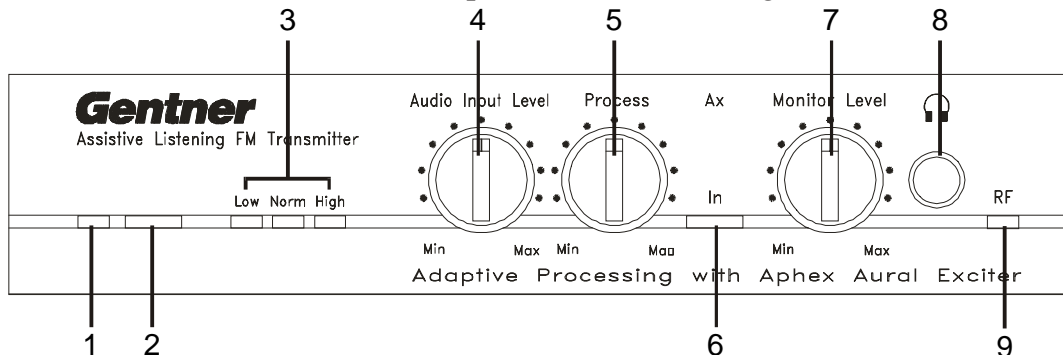



Figure 1. TX-37A front panel controls

- 1. Power LED.** This LED lights when power is applied.
- 2. Power Button.** This push-on/push-off button turns the TX-37A ON/OFF.
- 3. Audio Level LEDs.** These three LEDs indicate the incoming audio level:
 - Amber=Low
 - Green=Normal (occasional red flashes, 5–10 percent, acceptable)
 - Solid Red=High.
- 4. Audio Input Level.** This control adjusts the audio-input level. To set, slowly turn up the control (with audio playing) while monitoring the LED indicators [3], until the green LED is lit 90–95 percent of the time (red LED flashing occasionally, 5–10 percent).
- 5. Process.** This control sets the overall compression level. Set it wherever the effect is most pleasing (typically at 10 o'clock).
- 6. In.** This push-on/push-off button activates/deactivates the Aphex Aural Exciter process. This enhancement can be switched in and out.
- 7. Monitor Level.** This control sets the level of the audio at the  jack [8].

Front Panel
Continued ≡

8.  This headphone jack provides easy monitoring of transmitter operation. Its output is 1W, capable of driving most headphones.

HEADPHONE NOTE:

Ensure that the headphone jack does not make metal contact with the face plate of the TX-37A.

9. **RF.** This LED indicates proper RF-circuit function to simplify system troubleshooting (i.e. no signal being received). When lit, the LED indicates RF signal presence.

Back Panel
Controls ≡

The TX-37A's back-panel connectors and controls (See Figure 2, below.) are designed for ease in use.

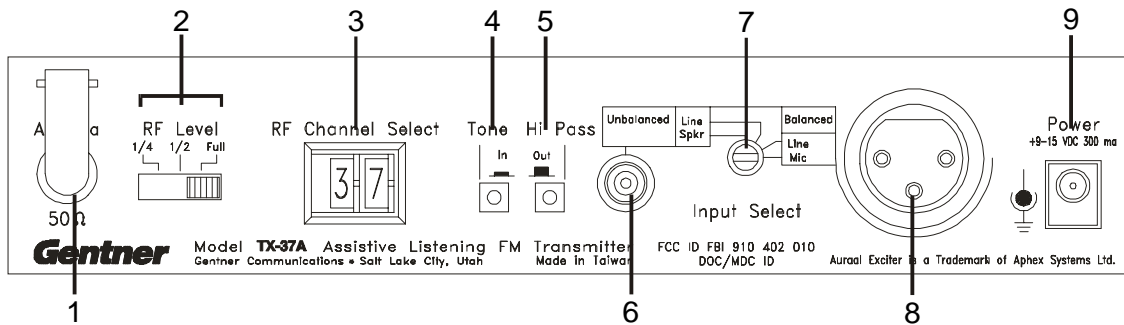

Figure 2. TX-37A back panel controls

1. **Antenna.** This 50 Ohm output is for connection of the supplied local antenna or the remote antenna (see Step 1, Page 6). *Do not operate the transmitter without the antenna.*

2. **RF Level.** This switch sets the RF output to one-quarter, half or full power to control the amount of coverage and to reduce the chance of interference.

3. **RF Channel Switch.** RF channels can be changed by setting the thumbwheel to any channel from 01–37. The corresponding frequencies are indicated on the top of the transmitter. If set other than 01–37, the system defaults to channel 01.

4. **Tone.** This switch sends a 40Hz test tone through the audio circuit to test the transmitter and aid in tuning receivers. To tune receivers, set the transmitter to the desired operating channel, activate the tone, then tune the receiver for clearest

reception. (Refer to receiver user's guide.)

5. Hi Pass. This switch activates the high-pass filter, which rolls off low frequencies below 180Hz (i.e., wind noise and room reverberation). These low frequencies are not needed for voice intelligibility.

6. Unbalanced. This unbalanced RCA audio input jack is a 10 kOhm input intended for connection of unbalanced signals from line/speaker-level outputs.

7. Input Select. This screwdriver-set control selects the input source from balanced mic and line-level signals to unbalanced line and speaker-level signals.

8. Ballanced Input. The balanced audio input XLR connector is 600 Ohms, transformer balanced, for balanced mic and line level-input signals.

9. Power. The TX-37A requires 11–15Vdc at 500mA, supplied by the provided AC power supply, or by other sources (batteries, auto cigarette lighter).

Installation ≡

The TX-37A is designed for easy installation and setup. To install the TX-37A, follow these step-by-step instructions:

Step 1 — Antenna Connection

Attach the provided rubber whip antenna to the modified TNC connector [1] (Figure 2, Page 4). It may be installed directly on the rear of the TX-37A, or remotely mounted on the supplied antenna mount and 49-foot cable (Figure 3, below).

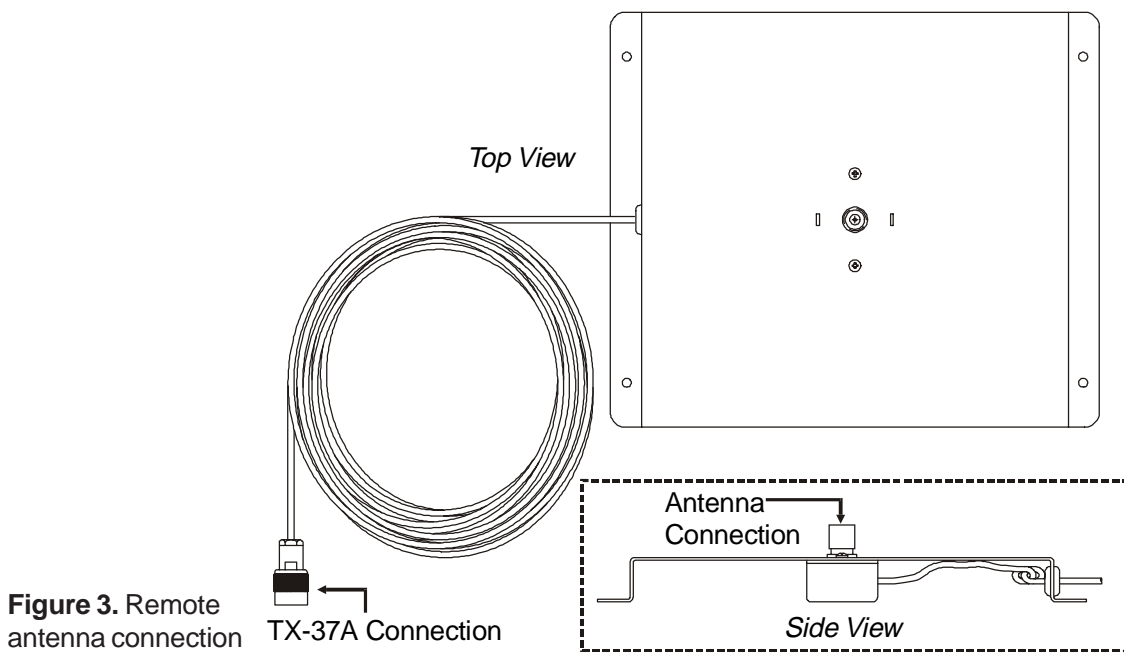

Unless the transmitter is used in a very small room, best performance is with the remote antenna placed away from the TX-37A, but as close to the receiver(s) as possible.

RACK-MOUNTING NOTE:

The remote antenna is necessary when rack-mounting the transmitter.

Position the remote antenna so it is not close to any vertical metal surface. If possible, place it on a horizontal metal surface to provide a ground plane and better performance. Main-

taining line of sight with the receivers is not always necessary, but will enhance reception. Walls containing large amounts of wiring, metal studs or concrete can block or reduce the transmitter signal.

RF SIGNAL NOTE:

Any RF system is susceptible to “dropouts” (reduced RF energy due to reflections and cancellations), which result in a noisy signal. It can usually be cured by moving the antenna around until the signal is clear. Some-times, even a few inches can dramatically alter performance.

Step 2 — Audio Connection

The TX-37A is designed to accommodate almost any type and level of audio source.

Microphone

Almost any 600 Ohm dynamic or self-powered condenser microphone can be plugged into the balanced XLR connector. When doing so, set the input select switch to MIC. An unbalanced microphone may be used with a suitable adapter. However, Gentner Communications recommends that a balanced microphone be used to eliminate noise pickup.

Line Input

The line input is most commonly used when connecting the TX-37A to a sound system amplifier or mixer (Figure 4, below).

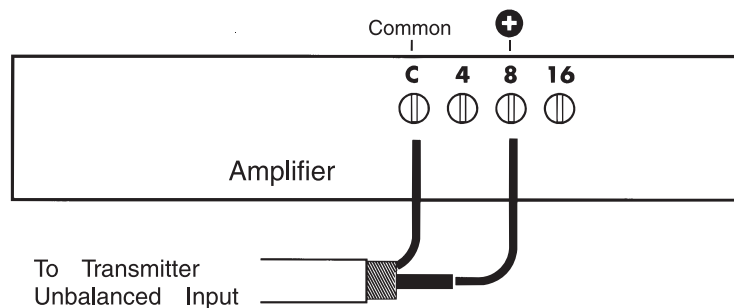

Figure 4. Amplifier connection

Installation
Continued ≡

If the source has a low impedance, balanced output (auxiliary, tape, etc.), use the XLR connector.

If a 10 kOhm unbalanced line or tape output is available (usually an RCA jack), use a suitable cable to connect this output to the RCA line input on the transmitter. After, set the input select switch to the proper position.

If you have a tape recorder or other device already connected to the line out, a Y cable (See Figure 5, below.) may be used to split the signal between the transmitter and the tape recorder. This type of adapter is generally available at electronic supply stores.

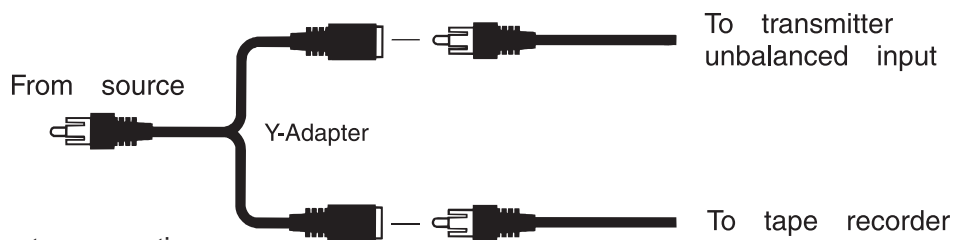

Figure 5. Y-adaptor connection

Speaker Input

If no suitable signals are available, the TX-37A can be connected to a speaker-level output (last resort). At these low levels, an amplifier output may be very noisy and subject to interference. Connect directly to the amplifier output, not to the remote speaker. If the transmitter is connected to the remote speaker and noise results, turn down the amplifier. The input to the transmitter is probably overdriven.

Step 3 — Apply Power

Plug the supplied AC adapter into a 110–120Vac power source, and plug the end of the cord into the sub-mini power jack. The front panel contains the push-on/push-off switch. Turn ON the power and monitor the front-panel

power LED. If the transmitter is receiving electricity, the LED will light.

Step 4 — Rack Mounting Option

The TX-37A may be rack mounted with the optional single-wide or double-wide rack mount kits. Contact Gentner Communications for kit availability and pricing.

Operation

The TX-37A is designed for ease in operation.

Set Audio Level

Turn the sound system and the transmitter ON, and provide a program source. Have someone speak into the microphone or connect an audio source to the sound system. Slowly raise the AUDIO INPUT LEVEL control [4] (See Figure 6, below.) until the amber and green LEDs are ON, and the red LED flashes 5–10 percent [3].

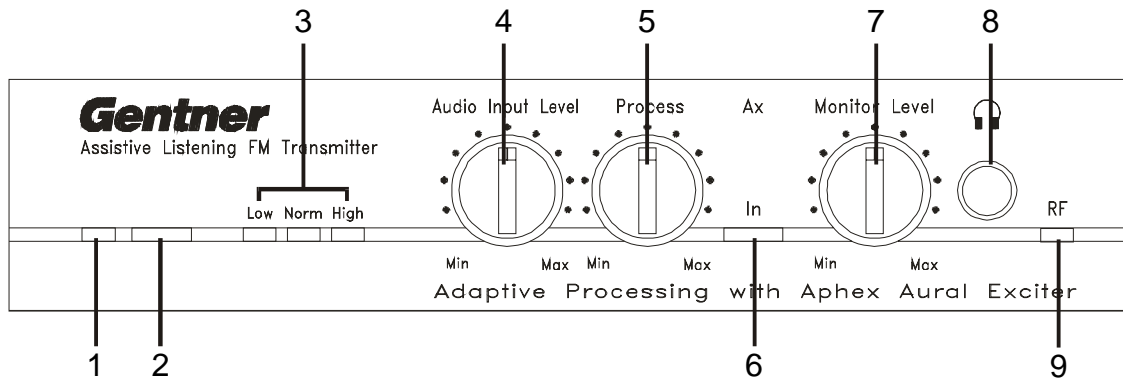

Figure 6. TX-37A front panel controls

The AUDIO INPUT LEVEL control [4] is typically set between 9 and 3 o'clock. If the input cannot be set easily with the front panel control, try setting the input select switch on the back panel to a higher or lower setting, or change the output level of your source device.

Operation Continued

High Pass Switch

If the system is to be used primarily with voice transmission, set the back panel HI PASS switch [5] to ON (Figure 7, below). This will cut low frequencies below 180Hz, reducing reverberation.

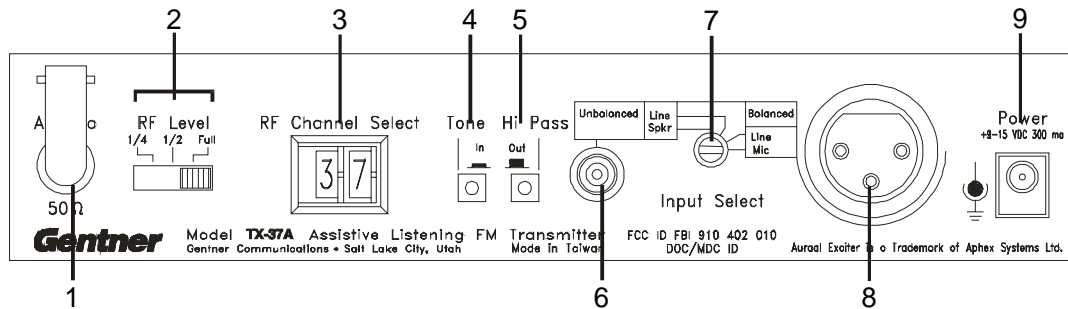

Figure 7. TX-37A back panel controls

Set the RF Level

Transmitters must *never* be set to the same frequency in the same location. Channels must be set as far apart from each other as possible. Test the reception with the RF level at one-half or one-quarter [2] power. The lower it can be operated satisfactorily, the less chance there will be for interference with another system. One-half or one-quarter power should cover most classroom applications.

Receiver Tuning

Set the TONE switch [4] to ON. To tune the receiver, refer to the respective receiver user's guide.

Reception Check

Using the tone or other audio source, walk around with the receiver. Verify the reception in all parts of the room. If reception is not optimal, move the transmitter antenna to another location and repeat this procedure.

Interference

With any type of RF device, other RF sources can interfere with reception. Even the FCC-designated ALS band is occasionally subject to use by other types of devices.

Interference can take the form of rising-and-falling audio. To verify on-channel interference, take the receiver to the place where the interference is worst and turn off the transmitter. The interfering signal should now come in stronger. Since the TX-37A is frequency-agile, you can set it to another channel and retune the receivers to move away from the interference.

If more than one TX-37A is to be operating in the same location, try to keep the channels used as far apart from each other as possible. Transmitters should never be set to the same frequency in the same location.

Service

The TX-37A contains no user-serviceable internal parts. Should a problem develop with the system that cannot be resolved by normal adjustments as described in this manual, contact Gentner Communications Corporation.

Specifications **TX-37A**

Dimensions

8.25"/20.96cmW x 1.75"/4.5cmH x 7.25"/
18.42cmD

Weight 2.5 lb./13 kg. (dry)

Audio Inputs

MIC: XLR, 600 Ohm balanced, 10mV
LINE: RCA, 600 Ohm balanced, 1V
LINE: RCA, 10K unbalanced, 1V
SPEAKER: RCA, unbalanced

Connectors

HEADPHONE: Phono
ANTENNA: Modified TNC, 50 Ohm
POWER: Sub-mini

Audio Performance

AGC Range

40dB

Manual Input Level Control

20dB

Signal to Noise Ratio

50dB

Transmission Type

FM modulation

Maximum Deviation

+/- 25kHz, 50kHz total

Maximum Radiated Power

8000V/m at 30M

Frequency Control

Digitally synthesized, crystal controlled

Frequency Stability

0.005%

Selectable Frequencies

37 channels between 72 MHz and 76 MHz

Power Requirements

9–15Vdc at 500mA

Notice 

The Gentner TX-37A Assistive Listening Transmitter complies with Part 15 of the FCC Rules.

Operation is subject to the following two conditions: 1) This device may not cause harmful interference, and 2) this device must accept any interference received, including interference that may cause any undesired operation.

Users are cautioned that changes or modifications not expressly approved by Gentner Communications Corporation could void the user's authority to operate the equipment.

FCC Registration Number: FBI 910 402 010

If you experience problems with this equipment, contact Gentner Communications Corporation. Aural Exciter® is a Registered Trademark of Aphex Systems, Inc.

Warranty 

Gentner Communications Corporation (Manufacturer) warrants that this Assistive Listening System (ALS) product is free of defects in both materials and workmanship. Should any part of this equipment be defective, Manufacturer agrees, at its option, to:

- A. Repair or replace any defective ALS product, free of charge (except transportation charges), for a period of one year from the date of the original purchase, provided the owner returns the equipment to the Manufacturer at the address set forth below. No charge will be made for parts or labor during this period;
- B. Furnish replacement for any defective ALS product parts in the equipment for a period of one year from the date of original purchase. Replacement parts shall be furnished without charge, except labor and transportation;
- C. Repair or replace any defective ALS accessory, free of charge (except transportation charges), for a period of 60 days from the date of the original purchase, provided the owner returns the equipment to the Manufacturer at the address set forth below. No charge will be made for parts or labor during this period.

This Warranty excludes assembled products not manufactured by Manufacturer whether or not they are incorporated in a Manufacturer product or sold under a Manufacturer part or model number.

THIS WARRANTY IS VOID IF:

- A. The equipment has been damaged by negligence, accident, act-of-God or mishandling, or has not been operated in accordance with the procedures described



Warranty
Continued ≡

- in the operating and technical instructions; or,
- B. The equipment has been altered or repaired by other than Manufacturer or an authorized service representative of Manufacturer; or,
- C. Adaptations or accessories other than those manufactured or provided by Manufacturer have been made or attached to the equipment which, in the determination of Manufacturer, shall have affected the performance, safety or reliability of the equipment; or,
- D. The equipment's original serial number has been modified or removed.

NO OTHER WARRANTY, EXPRESS OR IMPLIED, INCLUDING WARRANTY OF MERCHANTABILITY OR FITNESS FOR ANY PARTICULAR USE, APPLIES TO THE EQUIPMENT, nor is any person or company authorized to assume any warranty for Manufacturer or any other liability in connection with the sale of Manufacturer's products.

Manufacturer does not assume any responsibility for consequential damages, expenses or loss of revenue or property, inconvenience or interruption in operation experienced by the customer due to a malfunction in the purchased equipment. No warranty service performed on any product shall extend the applicable warranty period.

In case of unsatisfactory operation, the purchaser shall promptly notify Manufacturer at the address set forth below in writing, giving full particulars as to the defects or unsatisfactory operation, upon receipt of such notice, Manufacturer will give instructions respecting the shipment of the equipment, or such other matters as it elects to honor this warranty as above provided. This warranty does not cover damage to the equipment during shipping and Manufacturer assumes no responsibility for such damage. All shipping costs shall be paid by customer.

This warranty extends only to the original purchaser and is not assignable or transferable.

Gentner Communications Corp., 1825 Research Way, Salt Lake City, UT 84119

Appendix A:
System Diagram ≡

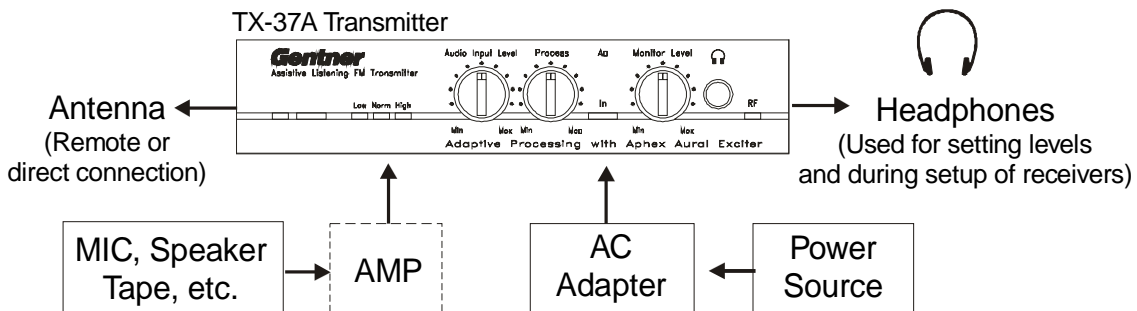



*“We are a technology innovation company
with a highly specialized service.”*



GENTNER COMMUNICATIONS CORPORATION

Sales and Technical Assistance

1825 Research Way

Salt Lake City, Utah 84119

Toll Free 800.945.7730

Telephone 801.975.7200

FAX 801.977.0087

FAX-On-Demand 800.695.8110

FAX-On-Demand International Line 801.974.3661

Worldwide Web Page @ <http://www.gentner.com>

Gentner Part No. 800-402-010 (Rev. 2.1)