



---

*Hybrid Coupler*

---

*Installation and  
Operations Manual*

**Copyright  
Information** ≡

© Copyright 1997 Gentner Communications Corporation. All rights reserved. No part of this manual may be reproduced in any form or by any means without written permission from Gentner Communications Corporation. Printed in the United States of America. Original version, 1/93. Gentner Communications Corporation reserves specification privileges. Information in this manual is subject to change without notice.

**Hybrid Coupler Installation and Operations Manual**

*Gentner Part No. 800-035-0011 (Rev. 2.00)*

*May 1997*

**Manual Development:** Bill Kilpack

**Artwork and Illustrations:** Jim Wright, Michael Greenhalgh, Bill Kilpack



Gentner Communications Corporation is committed to protecting the environment and preserving our natural resources.

This manual has been printed entirely on recycled paper.

## Contents

Introduction	1
Warranty Registration	1
Unpacking	1
Product Description	2
Hybrid Coupler	2
Front-Panel Controls	2
Back-Panel Connectors	2
Before You Install	3
Telephone Line Requirements	2
Equipment Placement	2
Installation	3
Completed Installation	3
Step 1 — Back-Panel Connections	3
Step 2 — Limiter Option	3
Null Adjustment	5
Step 1 — Verify Proper Installation	5
Step 2 — Connect Typical Audio	5
Step 3 — Place a Call	5
Step 4 — Adjust Null	5
Operation	6
Recording Daily Phone Calls	6
Simple Remotes/Production Studio Feeds	7
Specifications	9
Warranty	8
Appendix A: Telephone Theory	10
Appendix B: Theory of Operation	11
Appendix C: Schematics	12

## List of Figures

Figure 1. Equipment diagram	1
Figure 2. Hybrid Coupler front panel	2
Figure 3. Hybrid Coupler back panel	2
Figure 4. Hybrid Coupler completed installation	3
Figure 5. Send input connector	3
Figure 6. RJ11C jack	3
Figure 7. Berg jumper locations	4
Figure 8. Hybrid Coupler front panel	4
Figure 9. Null adjustment	5
Figure 10. Hybrid Coupler PC board	6
Figure 11. Hybrid Coupler front panel	6
Figure 12. Recording phone calls diagram	7
Figure 13. Simple remote diagram	7
Figure 14. Subscriber interface circuit schematic	10
Figure 15. Ideal telephone line	10

**Introduction** ≡

Congratulations on purchasing the Hybrid Coupler. The Hybrid Coupler is a two-way passive telephone coupler that allows the operator to simultaneously send and receive audio over a single telephone line. The unit connects directly to the telephone line and can be used with almost any analog or digital telephone system.

This manual explains how to install, set up and operate the Hybrid Coupler in a step-by-step format. It also supplies instructions on how to resolve technical problems, should any arise.

If you need any additional information on how to install, set up or operate your system, please contact us at Gentner Communications at the location noted below. We welcome and encourage your comments so we can continue to improve our products and serve your needs.

**Gentner Communications Corporation**

1825 Research Way  
Salt Lake City, UT 84119

TEL: Worldwide 801.975.7200 In U.S.A. 800.945.7730

FAX: Worldwide 801.977.0087 In U.S.A. 800.933.5107

FAX-On-Demand 24-Hour Information Service 800.695.8110

FAX-On-Demand International Line 801.974.3661

Worldwide Web Page @ <http://www.gentner.com>

**Warranty Registration**

Please register your Hybrid Coupler by completing the self-addressed, postage prepaid warranty registration card and return it to Gentner Communications by mail. You may also FAX it to the above listed fax number or call Gentner Communications. When your product is properly registered, Gentner Communications will be able to serve you better should you require technical assistance or desire to receive upgrades, new product information, etc.

**Unpacking** ≡

Ensure that the following items (See Figure 1, below.) were received with your shipment:

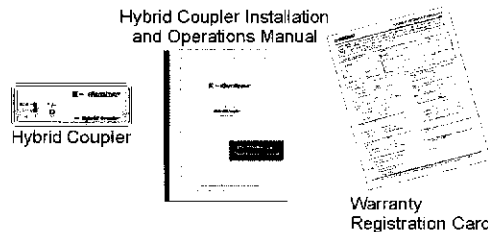

Figure 1. Equipment diagram

**SHIPPING NOTE:**

*Gentner Communications is not responsible for product damage incurred during shipment. You must make claims directly with the carrier. Inspect your shipment carefully for obvious signs of damage. If the shipment appears to be damaged, retain the original boxes and packing material for inspection by the carrier. Contact your carrier immediately.*

**Product Description**

**Hybrid Coupler**

The Hybrid Coupler is a two-way, passive telephone coupler. This means that it allows the operator to simultaneously send and receive audio over a single telephone line without external or internal power for operation.

Its primary application is sending and/or receiving audio over telephone lines. The unit connects directly to the telephone line and can be used with almost any analog or digital telephone system.

**Front-Panel Controls**

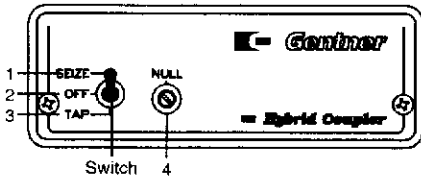

Figure 2. Hybrid Coupler front panel

When the switch on the front of the Hybrid Coupler (See Figure 2, left.) is in the TAP position [3], the internal hybrid coil is connected to the telephone line through a coupling capacitor. This permits the unit to monitor the telephone line without seizing or loading it.

With the switch on the front of the Hybrid Coupler in the SEIZE position [2], the hybrid coil is directly connected to the telephone line, which terminates the line. This allows the operator to hang up the telephone set and maintain an open telephone line.

When in the OFF position [2], the internal hybrid coil is not connected to the telephone circuit.

The Hybrid Coupler's internal hybrid coil provides approximately 10dB of audio separation (null) between the incoming receive and outgoing send audio. The amount of separation can be adjusted slightly with the front-panel NULL trim pot [4].

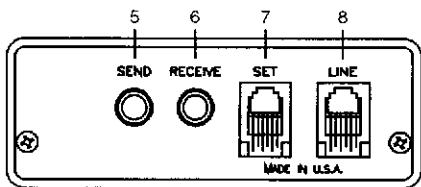

Figure 3. Hybrid Coupler back panel

**Back-Panel Connectors**

The Hybrid Coupler's telephone LINE [8] and SET [7] connectors (See Figure 3, left.) are paralleled connections to an internal hybrid coil.

The SEND [5] and RECEIVE [6] jacks are unbalanced audio feeds to and from the internal hybrid coil.

**Before You Install**

The Hybrid Coupler is designed to couple seamlessly with almost any analog or digital telephone line. However, to maximize your installation process, prepare your site by taking the following factors into consideration:

**Telephone Line Requirements**

The Hybrid Coupler accommodates standard telephone lines and connects to the telephone system (analog or digital) with a standard RJ11C modular jack. If you do not have an RJ11C jack where you want to install your Hybrid Coupler, call your telephone company for installation.

**Equipment Placement**

The Hybrid Coupler, being portable, is designed for easy placement in any of a wide variety of small, enclosed spaces. The only requirement is that it be placed close enough for cable connections to telephone line and system and any other outside audio equipment.

## Installation

The Hybrid Coupler is designed for easy installation and setup. All necessary interface connections are made through rear-panel jacks. This allows for easy installation, removal and service. To install your Hybrid Coupler, follow these instructions:

### Completed Installation

When installation is complete, the Hybrid Coupler configuration should resemble Figure 4 (left).

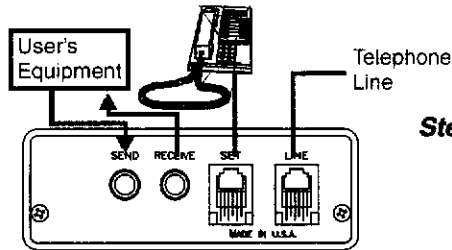

Figure 4. Hybrid Coupler completed installation



Figure 5. Send input connector

### Step 1 — Back-Panel Connections

#### Send

The Hybrid Coupler's SEND input [5] (See Figure 3, previous page; Figure 5, left.) consists of a single quarter-inch phone jack. Any audio applied to this input will be sent to the caller. The level of send audio is determined by the level of the source and the position of an internal limiter jumper option. The limiter option is detailed in Step 2 — Limiter Option (Page 4).

#### AUDIO WIRING NOTE:

To connect an active balanced audio source to the Hybrid Coupler's SEND input or RECEIVE output, Gentner Communications recommends that a ground of source equipment be connected to the SLEEVE and that the (+) audio side be connected to the TIP. If a transformer-coupled balance source is to be used, in addition to the wiring noted in Figure 4, the (-) audio should be connected to sleeve.

#### Receive

The Hybrid Coupler's RECEIVE output [6] also consists of a single quarter-inch phone jack. This output is unbalanced (referenced to the unit's ground) and has the electrical connections specified in Figure 5 (above):

When active, the unit delivers caller audio to this connector. The Hybrid Coupler does not amplify its receive port; thus, the output is typically at phone line level or -20dBm.

#### RECEIVE OUTPUT NOTE:

The Hybrid Coupler's receive output is never muted. In the OFF position, the SEND to RECEIVE level is approximately unity gain with severe distortion.

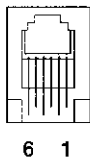

Figure 6. RJ11C jack

#### Set

The SET connector [7] is a standard RJ11C connector (Figure 6, left). Plug a telephone to this jack.

#### Line

The LINE connector [8] is also a standard RJ11C connector. Plug the telephone line into this jack.

### Step 2 — Limiter Option

The Hybrid Coupler incorporates both a send-level limiter and a receive-level limiter. These limiters are maximum level clippers. If the limiter is jumpered ON, the maximum possible transmitted or received level is 2.2V peak to peak (approximately 0dBm).

**Installation**  
**Continued** ≡

Gentner Communications ships the Hybrid Coupler with these limiters jumpered ON. If this default setting is sufficient, installation is complete.

However, if these limiters need to be jumpered OFF in your application, follow the instructions below:

**Step 1**

Disconnect all inputs and outputs.

**Step 2**

Remove the two front panel mounting self-tapping, black anodized screws and place them where they will not be lost.

**Step 3**

Slide the internal assembly of the unit out of its enclosure by its black bezel.

**Step 4**

The berg jumper strip for the send and receive limiters are clearly marked on the printed circuit board (See Figure 7, below.), and can be easily determined which position is shunted or active.

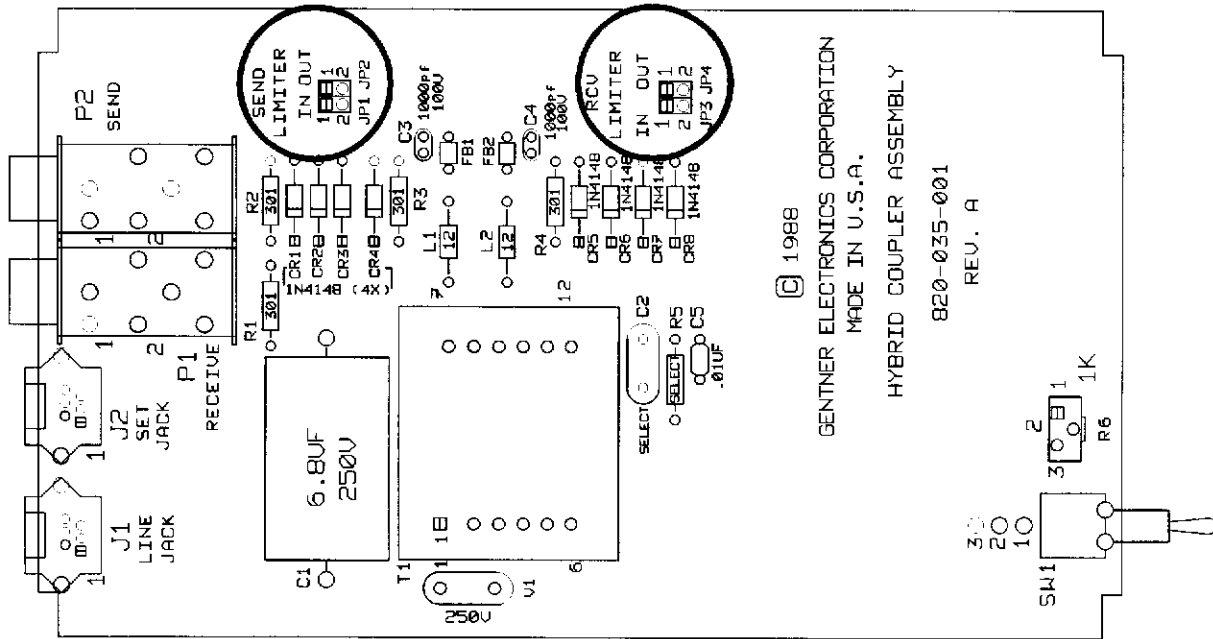

Figure 7. Berg jumper locations

**Step 5**

To change the shunting post from ON to OFF (or vice versa) simply lift the jumper off the berg dual-row strip and move it to the position required.

**Step 6**

Reassemble the unit and reinstall it.

Installation is now complete.



## Null Adjustment

The Hybrid Coupler, being an analog device, must be adjusted to optimize its performance. Gentner Communications test personnel adjust the Hybrid Coupler's null setting to a point acceptable for most applications. However, in some applications, it is necessary to change the null setting to accommodate line conditions of external equipment. Follow these step-by-step instructions:

### Step 1 — Verify Proper Installation

Ensure that the Hybrid Coupler is properly installed.

### Step 2 — Connect Typical Audio

Connect typical send audio to the SEND jack (i.e. recorded messages, test tones, outputs of preamps, etc.).

#### CRITICAL ADJUSTMENT NOTE:

*Gentner Communications recommends (if possible) connecting a 400Hz, 0dBm test tone to the SEND input if critical null adjustments are required.*

### Step 3 — Place a Call

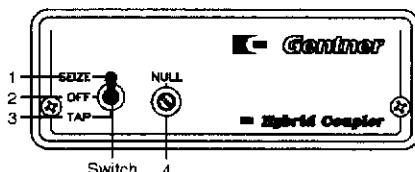

Figure 8. Hybrid Coupler front panel

Call the Hybrid Coupler from a different telephone set and then move the front panel switch to the SEIZE position [1] (figure 8, left). (This connects the call just placed through the Hybrid Coupler.)

Set the telephone handset down in a quiet environment to prevent caller audio from being detected as send-to-caller distortion.

### Step 4 — Adjust Null

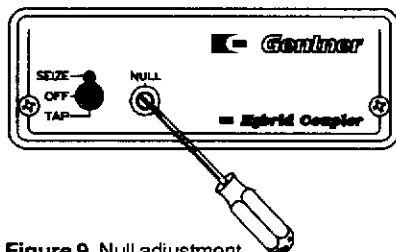

Figure 9. Null adjustment

Using a small flat screwdriver (See Figure 9, left.), adjust the front-panel NULL trim pot [4] until the send source appears at the RECEIVE output at its lowest level.

#### NULL ADJUSTMENT NOTE:

*A quick way to judge receive level is to attach an AC voltmeter to the RECEIVE output jack between the sleeve and tip.*

The Hybrid Coupler also has additional circuit connections to add extra resistive and capacitive components if the null adjustment needs further fine tuning. These connections are screened C2 and R5 on the unit's printed circuit board assembly (Figure 10, next page, top). Gentner Communications ships the Hybrid Coupler with quick solder-free clips for these connections.

Please use wise electro-mechanical techniques when making any modification to prevent damaging the Hybrid Coupler.

#### RESISTANCE NOTE:

*By adding a small additional capacitor to the C2 posts, the null deepens by only 2-3dB at a single frequency. Rarely will additional resistance be required (besides the front panel 1kOhm NULL trim pot) to optimize the Hybrid Coupler's hybrid performance.*

**Null Adjustment**  
**Continued** ≡

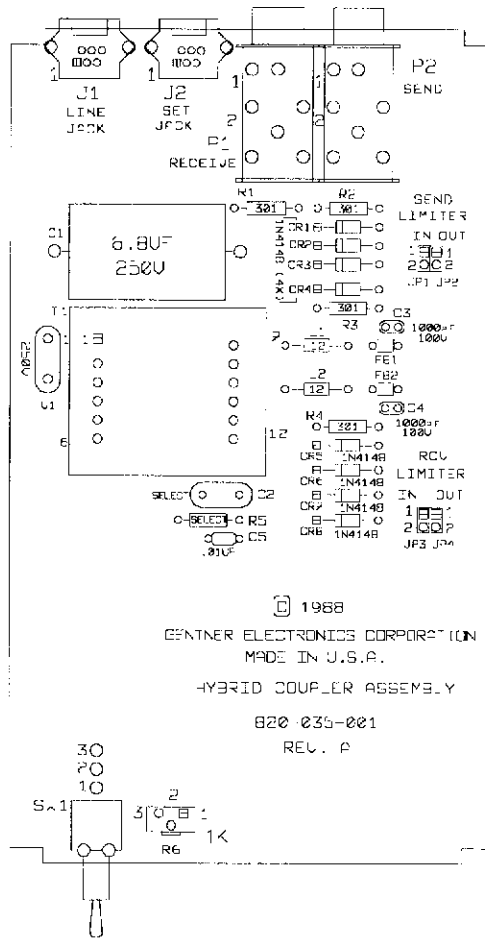

Figure 10. Hybrid Coupler PC board

**Operation** ≡

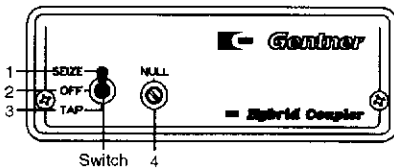

Figure 11. Hybrid Coupler front panel

The Hybrid Coupler is easy to control. By positioning the toggle switch on the unit's front panel (See Figure 11, left.), the Hybrid Coupler can be either OFF [2], SEIZED [1] or TAPPED [3] to the telephone line.

If this switch is in the OFF position [2], the Hybrid Coupler is not connected to the phone circuit.

If this switch is in the SEIZE position [1], the Hybrid Coupler is connected. In other words, any telephone line plugged to the rear panel LINE jack will be connected, and the SEND and RECEIVE jacks will be active.

If this switch is in the TAP position [3], the Hybrid Coupler is only *monitoring* the phone circuit. This means that if the phone line connected to the unit is in use (either by having a telephone instrument connected to the SET rear panel modular jack off-hook, or if supervisory current is being drawn elsewhere from that phone loop), the Hybrid Coupler's SEND and RECEIVE jacks will become active.

**Recording Daily Phone Calls**

A typical application for the Hybrid Coupler is monitoring and/or recording phone calls in progress with the TAP feature. To do this, follow the steps below:

- Step 1**  
Verify proper installation.

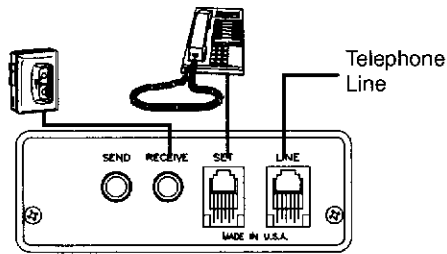

Figure 12. Recording phone calls diagram

**Step 2**

Connect a telephone to the Hybrid Coupler's SET jack and a tape machine's record input to the Hybrid Coupler's RECEIVE jack (Figure 12, left).

**Step 3**

Call someone and flip the switch on front of Hybrid Coupler to the TAP position [3].

**Step 4**

Start recording. The recorder will now pick up both ends of the conversation on the telephone line.

**Step 5**

When the conversation is complete, hang up the telephone set, return the Hybrid Coupler switch to the OFF position [2] and stop the recorder.

**Simple Remotes/Production Studio Feeds**

The Hybrid Coupler can be used to provide fast connection to the telephone network for remote audio feeds, news actualities, field reporting, etc. To do this, follow these instructions:

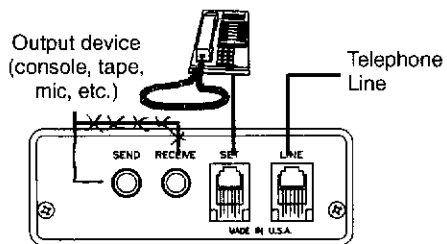

Figure 13. Simple remote diagram

**Step 1**

Verify proper installation.

**Step 2**

Connect audio feed output to the Hybrid Coupler's SEND jack (Figure 13, left).

**Step 3**

Call someone, move the Hybrid Coupler switch to the SEIZE position [1] and hang up the telephone set. (This prevents double terminating the telephone line.)

The Hybrid Coupler is now set up to send the audio feed down the telephone line to the second party.

**Step 4**

When the audio feed is complete, return the Hybrid Coupler switch to the OFF position [2] to hang up the telephone line.

**Specifications** 

**Hybrid Coupler**

**Dimensions**

4.17"W x 1.61"H x 6.97"D

**Weight**

1 lb./.5kg (dry)      2 lbs./1kg (shipping)

**Connectors**

LINE:      RJ11C

LINE:      RJ11C

SEND:      1/4" phone Jack, -10dBm nominal, unbalanced 600 Ohms,  
internal limiter selectable

RECEIVE:    1/4" phone Jack, -20dBm nominal, unbalanced 600 Ohms,  
internal limiter selectable

**Audio Performance**

**Frequency Response**

250Hz to 3.2kHz, +/- .1dB

**Signal-to-Noise Ratio**

> 60dB

**Distortion**

< .1% THD

**Null**

10dB nominal @ 1kHz, adjustable

**SPECIFICATION NOTE:**

*All specifications referenced to -10dBm telephone level and an ideal telephone line.*

All specifications are subject to change without notice.

**Warranty** ≡

Gentner Communications Corporation (Manufacturer) warrants that this product is free of defects in both materials and workmanship. Should any part of this equipment be defective, the Manufacturer agrees, at its option, to:

A. Repair or replace any defective part free of charge (except transportation charges) for a period of one year from the date of the original purchase, provided the owner returns the equipment to the Manufacturer at the address set forth below. No charge will be made for parts of labor during this period;

B. Furnish replacement for any defective parts in the equipment for a period of one year from the date of original purchase. Replacement parts shall be furnished without charge, except labor and transportation.

This Warranty excludes assembled products not manufactured by the Manufacturer whether or not they are incorporated in a Manufacturer product or sold under a Manufacturer part or model number.

**THIS WARRANTY IS VOID IF:**

A. The equipment has been damaged by negligence, accident, act of God, or mishandling, or has not been operated in accordance with the procedures described in the operating and technical instructions; or,

B. The equipment has been altered or repaired by other than the Manufacturer or an authorized service representative of the Manufacturer; or,

C. Adaptations or accessories other than those manufactured or provided by the Manufacturer have been made or attached to the equipment which, in the determination of the Manufacturer, shall have affected the performance, safety or reliability of the equipment; or,

D. The equipments original serial number has been modified or removed.

NO OTHER WARRANTY, EXPRESS OR IMPLIED, INCLUDING WARRANTY OF MERCHANTABILITY OR FITNESS FOR ANY PARTICULAR USE, APPLIES TO THE EQUIPMENT, nor is any person or company authorized to assume any warranty for the Manufacturer or any other liability in connection with the sale of the Manufacturer's products.

Manufacturer does not assume any responsibility for consequential damages, expenses, or loss of revenue or property, inconvenience, or interruption in operation experienced by the customer due to a malfunction in the purchased equipment. No warranty service performed on any product shall extend the applicable warranty period.

In case of unsatisfactory operation, the purchaser shall promptly notify the Manufacturer at the address set forth below in writing, giving full particulars as to the defects or unsatisfactory operation. Upon receipt of such notice, the Manufacturer will give instructions respecting the shipment of the equipment, or such other matters as it elects to honor this warranty as above provided. This warranty does not cover damage to the equipment during shipping and the Manufacturer assumes no responsibility for such damage. All shipping costs shall be paid by the customer.

This warranty extends only to the original purchaser and is not assignable or transferable.

**Gentner Communications Corporation, 1825 Research Way, Salt Lake City, Utah 84119**

**Appendix A: Telephone Theory**

To better understand the application of Gentner telephone products, it is helpful to obtain a basic understanding of the telephone system.

The telephone company provides a single pair of wires for every telephone line within the service area of the Central Office (CO). The pair of wires are twisted to form a balanced transmission line. This twisting of two identical wires provides for the rejection of hum and noise on the telephone line. This single pair of wires provides simultaneous transmission of both send and receive audio, DC current to power the user's telephone, and ringing voltage signals. The diagram below (Figure 14) is a schematic of the subscriber interface circuit at the CO.

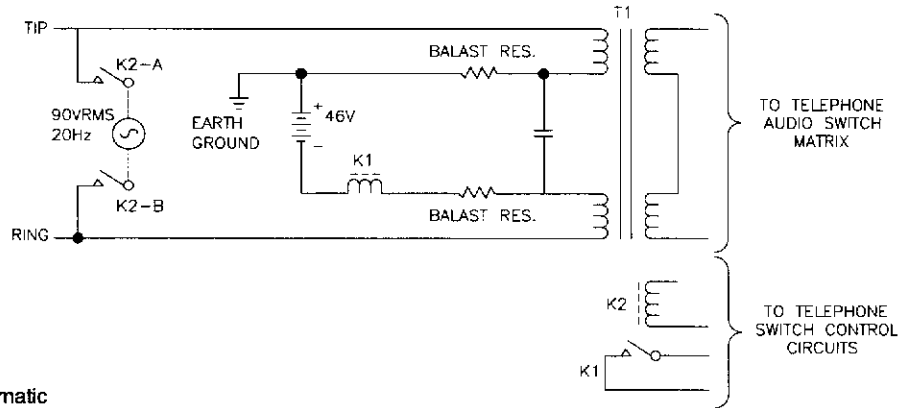

Figure 14. Subscriber interface circuit schematic

The two wires coming from the CO are called tip and ring. These names carry over from the days of the old manual switchboard when an operator manually interconnected callers with patch cords. The tip and the ring terminals of the plug on the patch cord provided the connections to the caller's telephone. It is very easy to identify tip and ring using a standard voltmeter; as Figure 14 indicates, tip is positive and ring is negative. The open circuit voltage on the telephone line is 48V.

When a telephone handset is taken off hook, current is drawn from the CO battery, closing the contacts of K1. These contacts tell the CO switching mechanism that the user demands service. The switch then provides dial tone and waits for the user to dial a number. If an incoming call is to be directed to a user, the CO switch will operate K2 and apply 90V (RMS) at 20Hz to tip and ring. This voltage now superimposed on the 48Vdc will cause the user's instrument to ring. When the called party takes the instrument off hook, K1 will close and the switch will interconnect the two parties.

Figure 15 (below) shows what the ideal telephone line looks like (simply two conductors between the user and the CO) compared to the actual telephone line.

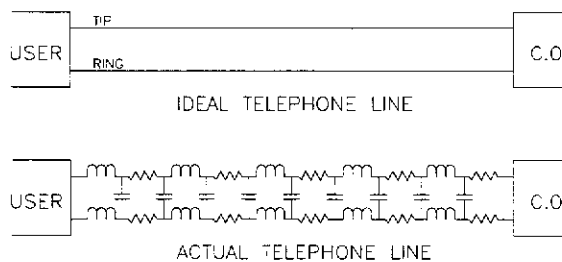

Figure 15. Ideal telephone line

Any wire conductor has a small amount of resistance and inductive reactance. As we increase the length of this conductor beyond 100 feet, these two components begin to have significant effects at audio frequencies. In addition, two of these conductors are twisted together, creating a significant amount of shunt

capacitance between the two wires. This distributed inductance, resistance and capacitance causes a loss at the higher audio frequencies. These two deficiencies in tandem limit the frequency response of the telephone line to a band that extends from 300–3,300Hz. Since capacitive and inductive reactance both change with frequency, the complex impedance of the telephone line will be different at every frequency in the voice band. The purpose of a telephone hybrid is to separate the full-duplex audio of a balanced phone circuit into separate send and receive audio ports.

This separation is very important to preserve the acoustic quality of the send audio. When audio is sent to a caller, it is transmitted on the telephone line. The acoustics of this audio are altered by the telephone line's frequency response. If some of this altered send audio gets mixed with the caller audio, the audio will sound hollow.

The measurement of a telephone hybrid's performance is how well it isolates, or attenuates, the send audio input port from the caller audio output port. This isolation can be optimized by adjusting the hybrid's null controls. When the impedance of the null circuit matches the impedance of the telephone line connected to the hybrid, a perfect null or attenuation of the send audio will result. However, as discussed earlier, the impedance of the telephone line is different for every frequency in the voice band, thus, making the perfect null impossible to achieve. Even though a perfect null is impossible, very satisfactory results can be obtained using this method for most applications.

## **Appendix B: Theory of Operation** ≡

The Hybrid Coupler is a simple device, both technically and in operation. Please refer to Appendix C: Schematics (next page) during the following discussion.

Telephone line connection to the unit is made via two RJ11 modular connectors. Pins 2 and 3 of these two connectors are tied together to allow simultaneous use of the unit and an attendant telephone set. The varistor (V1) is placed across the telephone line inside the unit for surge protection.

The Hybrid Coupler uses a PREM SPT-183 telephone coil to provide termination to the phone line. This coil is wound to provide a receive and send port with approximately 6dB of isolation. The components R6, the front panel 1kOhm trim pot, and C5, the .01uF null capacitor, allow for further impedance matching.

RFI protection is provided via L1, L2, FB1 and FB2 for both the send and receive ports of the T1 coil.



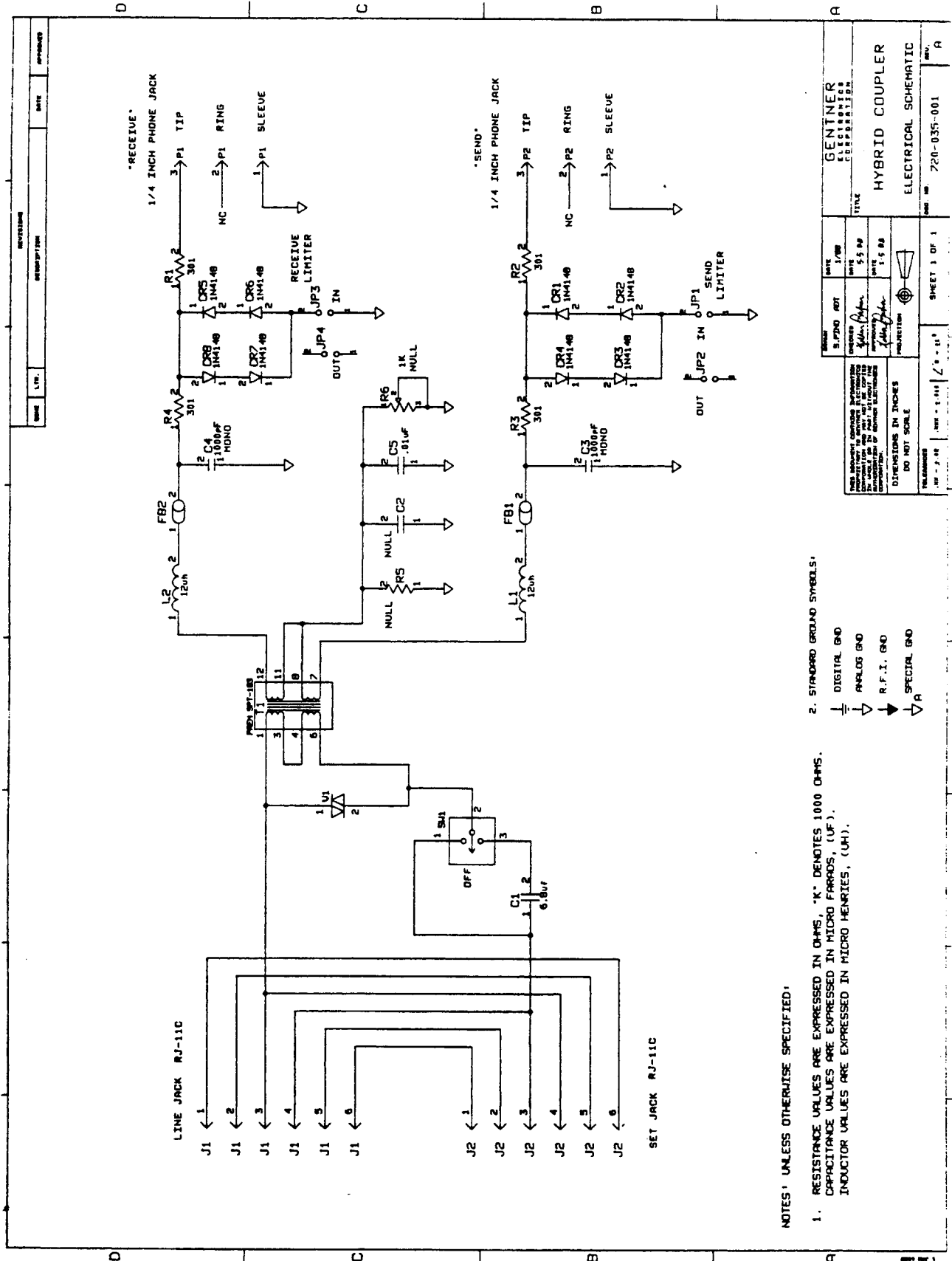

The resistors, R1–R4, are all 301 Ohm 1% components. These provide connection to the SEND and RECEIVE jacks and proper impedance matching for the PREM coil.

The send and receive limiters are constructed of back-to-back 1N4148 diodes, CR1 through CR8. Both of these limiters can be removed from the circuit via JP1, JP2, JP3 and JP4 placement of a berg shorting post.

**Appendix C:**  
**Schematics** 



NOTES: UNLESS OTHERWISE SPECIFIED:

- RESISTANCE VALUES ARE EXPRESSED IN OHMS. "K" DENOTES 1000 OHMS. CAPACITANCE VALUES ARE EXPRESSED IN MICRO FARADS, (UF). INDUCTOR VALUES ARE EXPRESSED IN MICRO HENRIES, (UH).
- STANDARD GROUND SYMBOLS:  
 DIGITAL GND  
 ANALOG GND  
 R.F.I. GND  
 SPECIAL GND